

Epoxy meets UL-94 V-0 flammability rating  
 Halogen free available upon request by adding suffix "HF"  
 Moisture Sensitivity Level 1  
 Low collector-emitter saturation voltage

**Mechanical Data**

**Package:** SOT-89  
 Molding compound meets UL 94 V-0 flammability rating,  
 RoHS-compliant, halogen-free  
**Terminals:** Tin plated leads, solderable per  
 J-STD-002 and JESD22-B102  
 Marking: BL

**Maximum Ratings** (Ta=25 unless otherwise noted)

Item	Symbol	Unit	Conditions	Value
Minimum Collector-Emitter Voltage	$V_{CEO}$	V	$I_C=10mA, I_B=0$	80
Minimum Collector-Base Voltage	$V_{CBO}$	V	$I_C=100\mu A, I_E=0$	100
Minimum Emitter-Base Voltage	$V_{EBO}$	V	$I_E=10\mu A, I_C=0$	5
Collector Current	$I_C$	A		1
Collector Power Dissipation	$P_C$	mW		500
Thermal Resistance From Junction To Ambient	$R_{JA}$	/W		250
Operation Junction Temperature	$T_j$			-55 to +150
Storage Temperature	$T_{stg}$			-55 to +150



# BCX56

## Electrical Characteristics (Ta=25 unless otherwise noted)

Item	Symbol	Unit	Conditions	Min	TYP	Max
Collector-Emitter Voltage	$V_{CEO}$	V	$I_C=10mA, I_B=0$	80		
Collector-Base Voltage	$V_{CBO}$	V	$I_C=100\mu A, I_E=0$	100		
Emitter-Base Voltage	$V_{EBO}$	V	$I_E=10\mu A, I_C=0$	5		
Collector-Base cut-off current	$I_{CBO}$	nA	$V_{CB}=30V$			100
Emitter-Base cut-off current	$I_{EBO}$	nA	$V_{EB}=5V$			100
DC Current Gain	$h_{FE1}$		$V_{CE}=2V, I_C=150mA$	63		250
	$h_{FE2}$		$V_{CE}=2V, I_C=5mA$	40		
	$h_{FE3}$		$V_{CE}=2V, I_C=500mA$	25		
Collector-Emitter Saturation Voltage	$V_{CE(sat)}$	V	$I_C=500mA, I_B=50mA$			0.5
Base-Emitter Voltage	$V_{BE}$	V	$V_{CE}=2V, I_C=500mA$			1
Transition Frequency	$f_T$	MHz	$I_C=10mA, V_{CE}=5V, f=100MHz$		130	

## Ordering Information (Example)

PREFERRED P/N	PACKING CODE	UNIT WEIGHT(g)	MINIMUM PACKAGE(pcs)	INNER BOX QUANTITY(pcs)	OUTER CARTON QUANTITY(pcs)	DELIVERY MODE
BCX56	F2	Approximate 0.055	1000	8000	32000	7" reel

## Characteristics (Typical)

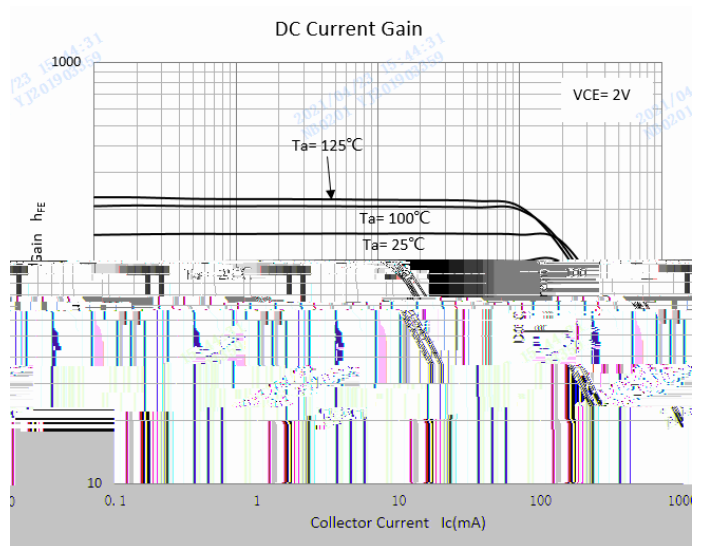
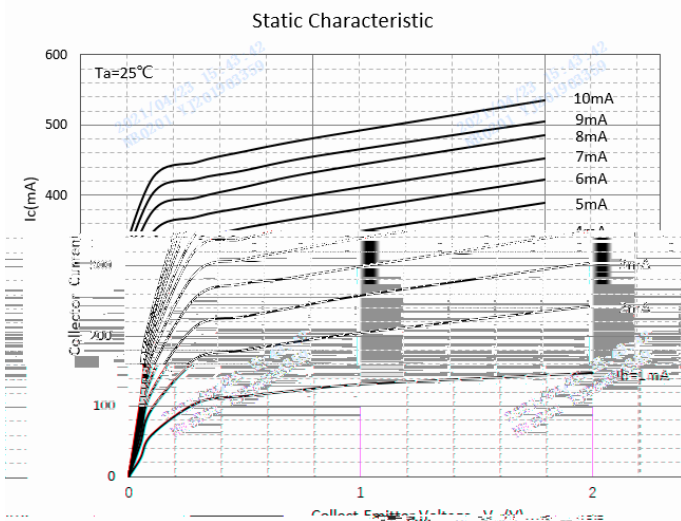



# BCX56

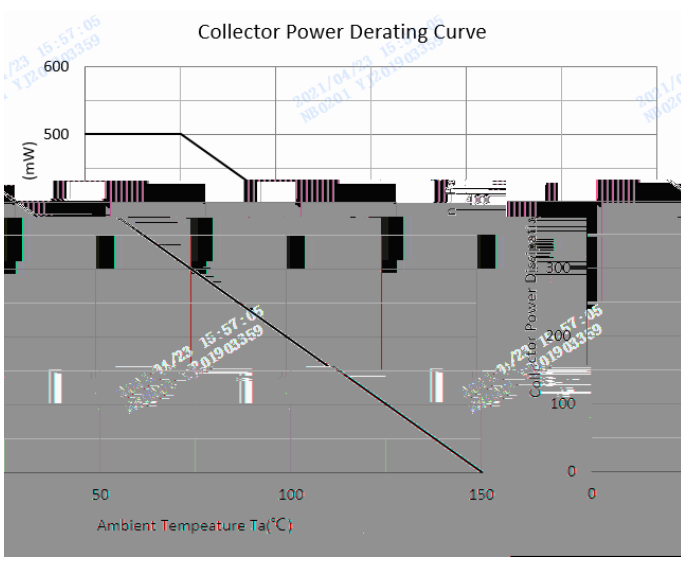
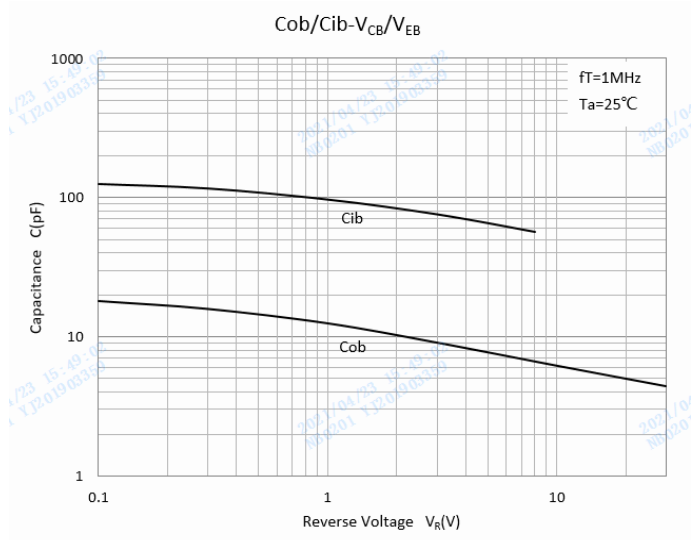
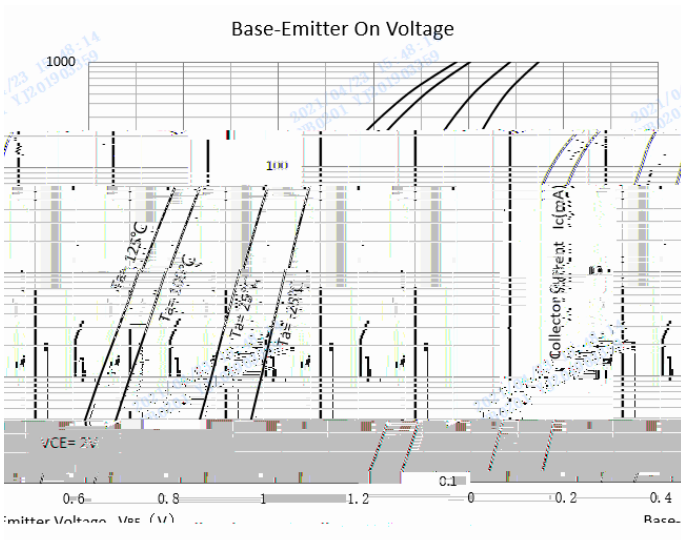
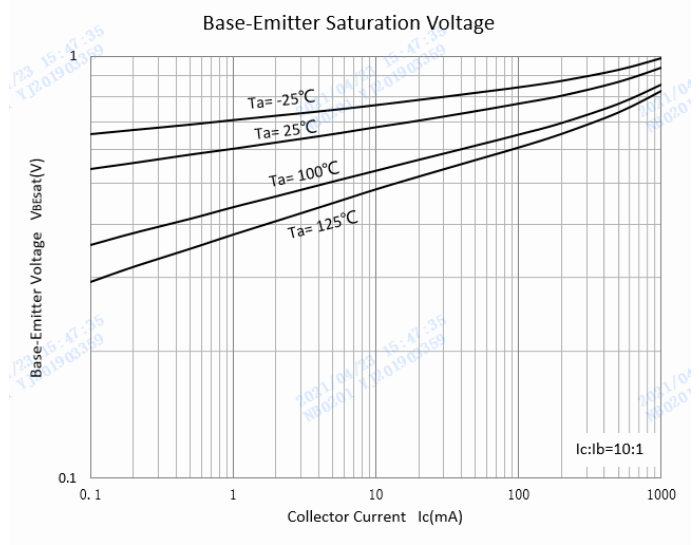
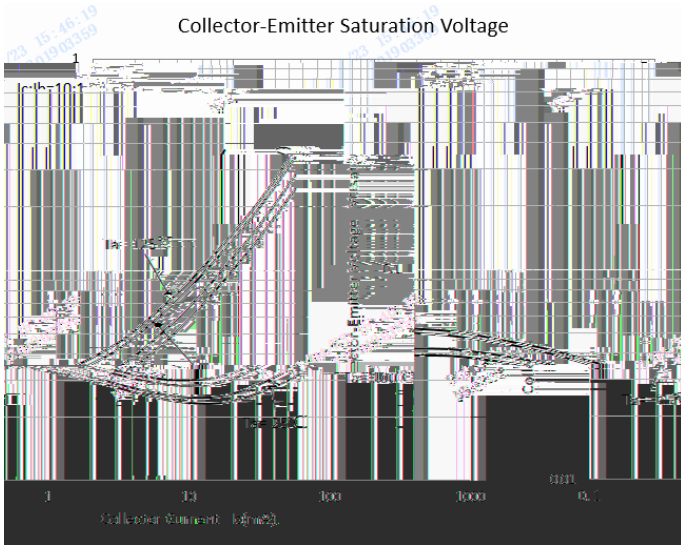



# BCX56

## SOT-89 Package Outline Dimensions

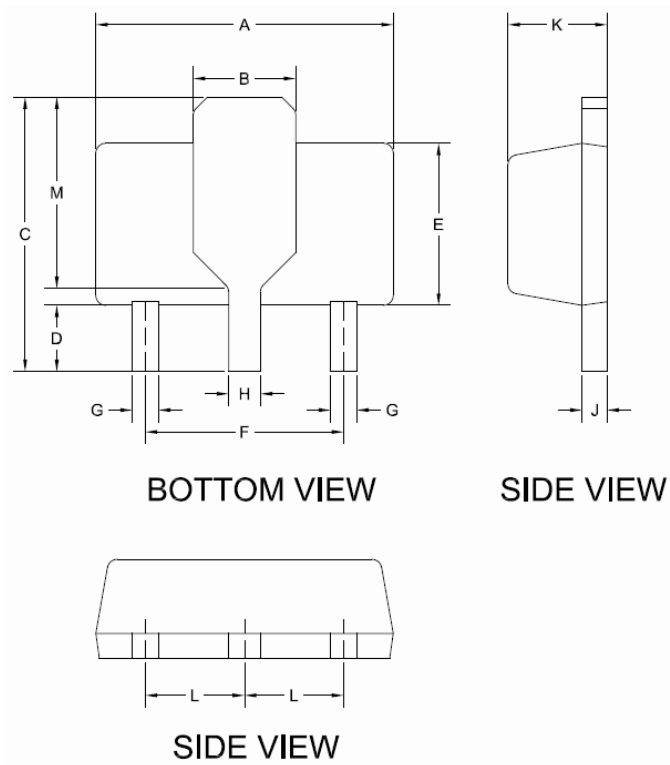

DIMENSIONS		DIMENSIONS		DIM	MIN.
MAX.	MIN.	MAX.	MIN.		
0.181	4.400	4.600		A	0.173
061 TYP.	1.550 TYP.			B	0.
0.167	3.940	4.250		C	0.155
0.047	0.800	1.200		D	0.031
0.102	2.400	2.600		E	0.094
118 TYP.	3.00 TYP.			F	0.
0.019	0.360	0.480		G	0.014
0.022	0.440	0.560		H	0.017
0.017	0.350	0.440		J	0.014
0.063	1.400	1.600		K	0.055
0.118	1.500	1.600		L	0.063
0.118 TYP.	2.750 TYP.			M	0.10

## SOT-89 Suggested Pad Layout

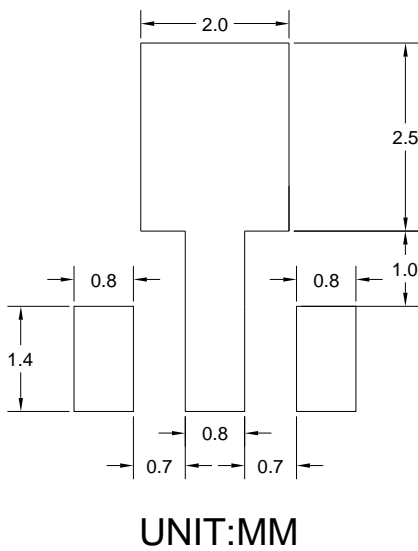



## Disclaimer

The information presented in this document is for reference only. Yangzhou Yangjie Electronic Technology Co., Ltd. reserves the right to make changes without notice for the specification of the products displayed herein to improve reliability, function or design or otherwise.

The product listed herein is designed to be used with ordinary electronic equipment or devices, and not designed to be used with equipment or devices which require high level of reliability and the malfunction of which would directly endanger human life (such as medical instruments, transportation equipment, aerospace machinery, nuclear-reactor controllers, fuel controllers and other safety devices), Yangjie or anyone on its behalf, assumes no responsibility or liability for any damages resulting from such improper use of sale.

This publication supersedes & replaces all information previously supplied. For additional information, please visit our website [http:// www.21yangjie.com](http://www.21yangjie.com) , or consult your nearest Yangjie's sales office for further assistance.